

## Carboxylic acid Derivatives

Carboxylic derivatives are described as compounds that can be converted to carboxylic acids via simple acidic or basic hydrolysis.

The most important acid derivatives are esters, amides and nitriles, although acid halides and anhydrides are also derivatives (really activated forms of a carboxylic acid).

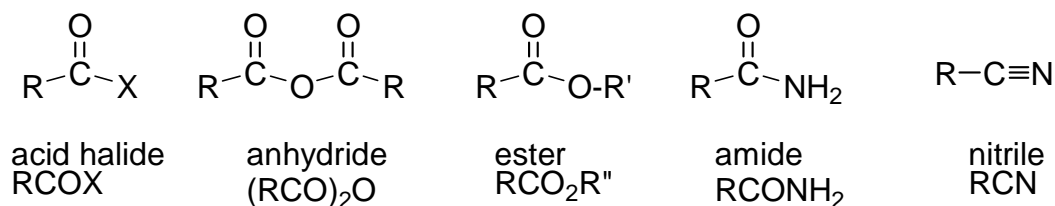

### Esters of Carboxylic Acids

These are derivatives of carboxylic acids where the hydroxyl group is replaced by an alkoxy group.

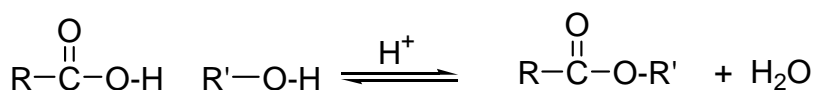

We have already seen that esters are produced via the reaction of an alcohol with a carboxylic acid.

### Nomenclature

The names of esters are derived from the names of the compounds that are used to create them.

The first word of the name comes from the alkyl group of the alcohol, and the second part comes from the carboxylate group of the acid used.

E.g.

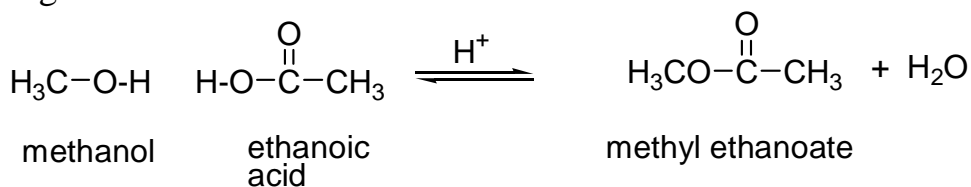

A cyclic ester is called a lactone, and IUPAC names of lactones are derived by adding the term lactone at the end of the name of the parent carboxylic acid it came from.

E.g.

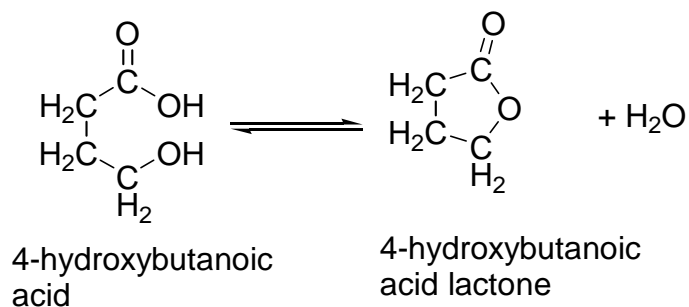

### Amides of Carboxylic Acids

An amide is a composite of a carboxylic acid and an amine (or ammonia).

Heating the salt formed when an amine and carboxylic acid react drives off the water produced, and an amide is formed.

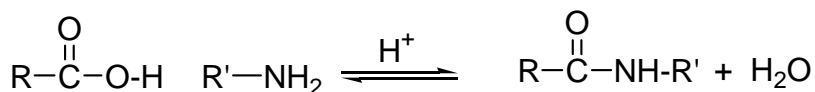

Amides are much less basic than their parent amines since the lone pair of electrons on Nitrogen are delocalized onto the carbonyl oxygen.

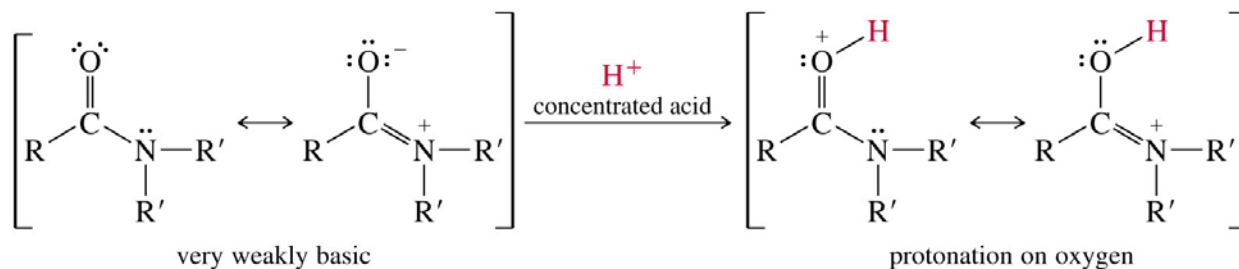

In fact in strong acid, it is the oxygen that gets protonated first!

This conjugation means the N should be  $sp^2$  hybridized, and indeed the amide nitrogen has a planar arrangement of bonds with bond angles close to  $120^\circ$ .

The C-N bond has partial double bond character, and the rotational barrier is 18kcal/mol.

Amides of the form  $R-CO-NH_2$  are called primary amides since the nitrogen is only bound to one carbon atom (like  $R-NH_2$  is primary).

Amides that are of the form  $R-CO-NHR'$  are called secondary amides, or N-substituted amides.

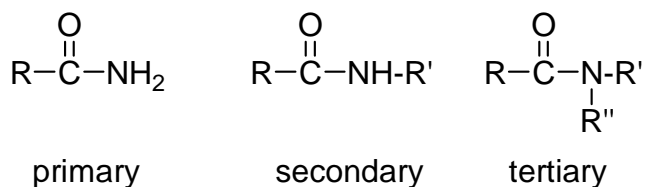

Amides of the form  $R-CO-NR_2$  are tertiary amides, or N,N-disubstituted amides.

## Nomenclature of Amides

To name a primary amide, identify the acid part and remove the -oic acid suffix and add -amide

E.g.

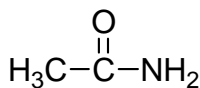

ethanamide

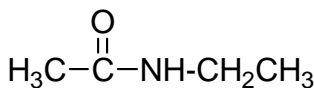

N-ethylethanamide

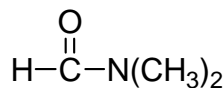

N,N-dimethylmethanamide

To name a secondary or tertiary amide, the alkyl groups on nitrogen are treated as substituents, and are given the prefix N (since they are the nitrogen).

Cyclic amides are known as **Lactams**.

Lactams are produced from amino acids, where the amino and the carboxylic acid groups react together to form an amide linkage.

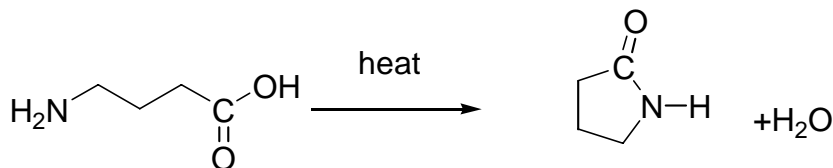

4-aminobutanoic acid

4-aminobutanoic acid lactam

They are named by adding the word lactam to the correct IUPAC name of the parent acid.

## Nitriles of Carboxylic Acids

Nitriles contain the cyano group, and although they lack the carbonyl group that the other carboxylic acid derivatives have, they are still classified as carboxylic acid derivatives since they are hydrolyzed to carboxylic acids, and also can be produced by dehydration of primary amides.

E.g.

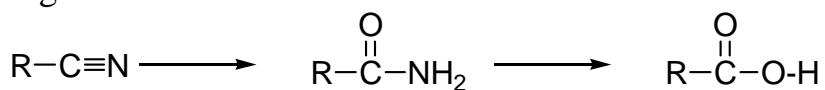

Both the carbon and nitrogen atoms of a nitrile are sp hybridized, and the bond angle is 180°.

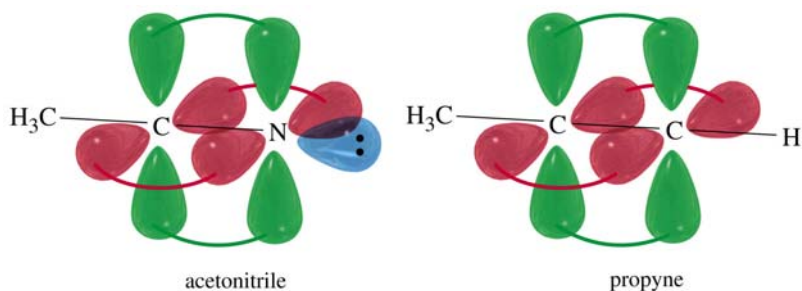

The structure of a nitrile is similar to an alkyne, except the nitrogen has a lone pair of electrons instead of a bond to hydrogen.

Since the lone pair on N is contained in an sp orbital, they are tightly held, and are therefore not very basic.

Normal nitriles have  $\text{p}K_b \sim 24$ .

## Nomenclature

IUPAC requires nitriles to be named based on the alkane name, with the suffix -nitrile added.

E.g.

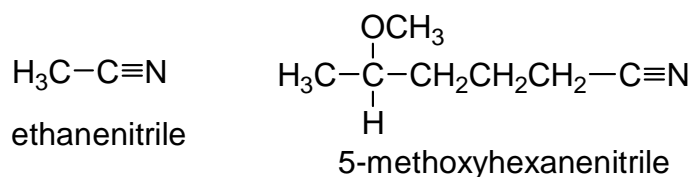

## Acid Halides

Acid (or acyl) halides are activated derivatives of carboxylic acids, and are often used to prepare the other carboxylic acid derivatives.

The most common examples of this class are acid chlorides, but acid fluorides, bromides and iodides do exist (but are rarely used).

The halogen atom inductively withdraws electron density away from the already electrophilic carbon of the carbonyl group.

Therefore acid halides are very reactive toward nucleophilic attack, and the overall reaction is nucleophilic acyl substitution since the chloride is a good leaving group.

### Nomenclature

Acid halides are named by taking the -ic acid suffix of the related carboxylic acid, replacing it with -yl, and adding the halide name.

E.g.

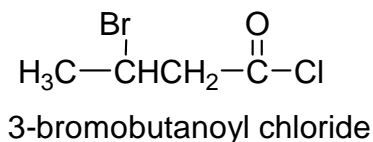
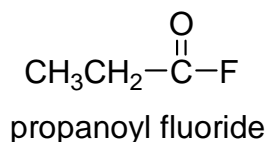

### Anhydrides of Carboxylic Acids

The word anhydride literally means without water, and an acid anhydride is the combination of two molecules of carboxylic acid with the elimination of one molecule of water.

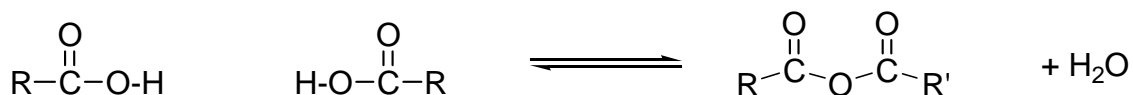

Anhydrides are also considered as **activated** forms of carboxylic acids, although anhydrides are not as reactive as acid halides.

The anhydride group also inductively withdraws electron density from the carbonyl carbon, and the carboxylate anion serves as a good leaving group.

Half of the anhydride is 'lost' as the leaving group, and if the carboxylic acid is very precious (expensive or limited quantity) then this is an undesirable way of making an activated carboxylic acid, and the acid chloride route would be more desirable.

## Nomenclature

(Simple) anhydrides are simply named by replacing the -acid suffix of the parent carboxylic acids with the word anhydride.

E.g.

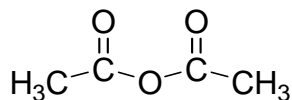

ethanoic anhydride

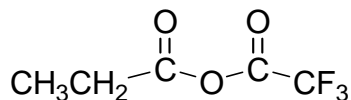

trifluoroethanoic propanoic anhydride

Mixed anhydrides that consist of two different acid derived parts are named using the names of the two individual acids, with the highest priority acid being the first name.

## Nomenclature of Multifunctional Compounds

We have now covered a wide variety of functional groups, and 'real' molecules contain many of these different functionalities.

How do we go about correctly naming these molecules?

In choosing the principal group for the root name, the following priorities are observed.

Acid > ester > amide > nitrile > aldehyde > ketone > alcohol > amine > alkene > alkyne

### Interconversion of Acid Derivatives

Acid derivatives undergo a variety of reactions under both acidic and basic conditions, and almost all involve nucleophilic acyl substitution.

There are a lot of transformations, but only one general mechanism:

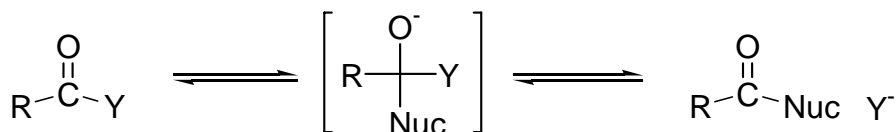

The nucleophile adds to the carbonyl group generating a tetrahedral intermediate, which in turn expels the leaving group whilst reforming the carbonyl C=O double bond.

The overall reaction is a **substitution**, not an addition.

This is another example of an addition - elimination mechanism.

By varying the nucleophile and leaving group, we can cover almost every reaction in this chapter.

In general, more reactive acid derivatives are converted into less reactive acid derivatives.

So this requires an understanding of which derivatives are more reactive than others.

### Reactivity of Acid Derivatives

The carboxylic acid derivatives vary **greatly** in their reactivities with nucleophiles.

For example acid chlorides hydrolyze in moist air, whereas amides hydrolyze slowly even in boiling alkaline water.

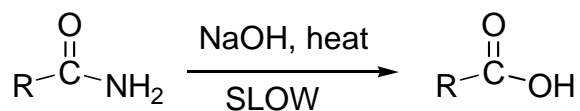
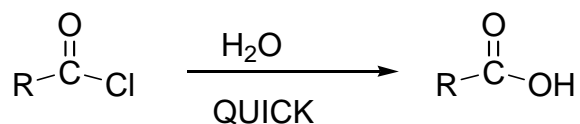

The reactivity depends on both the **structure** of the derivative and also on the **nature** of the nucleophile.

This order also correlates to the basicity of the leaving group.

Strong bases make poor leaving groups.

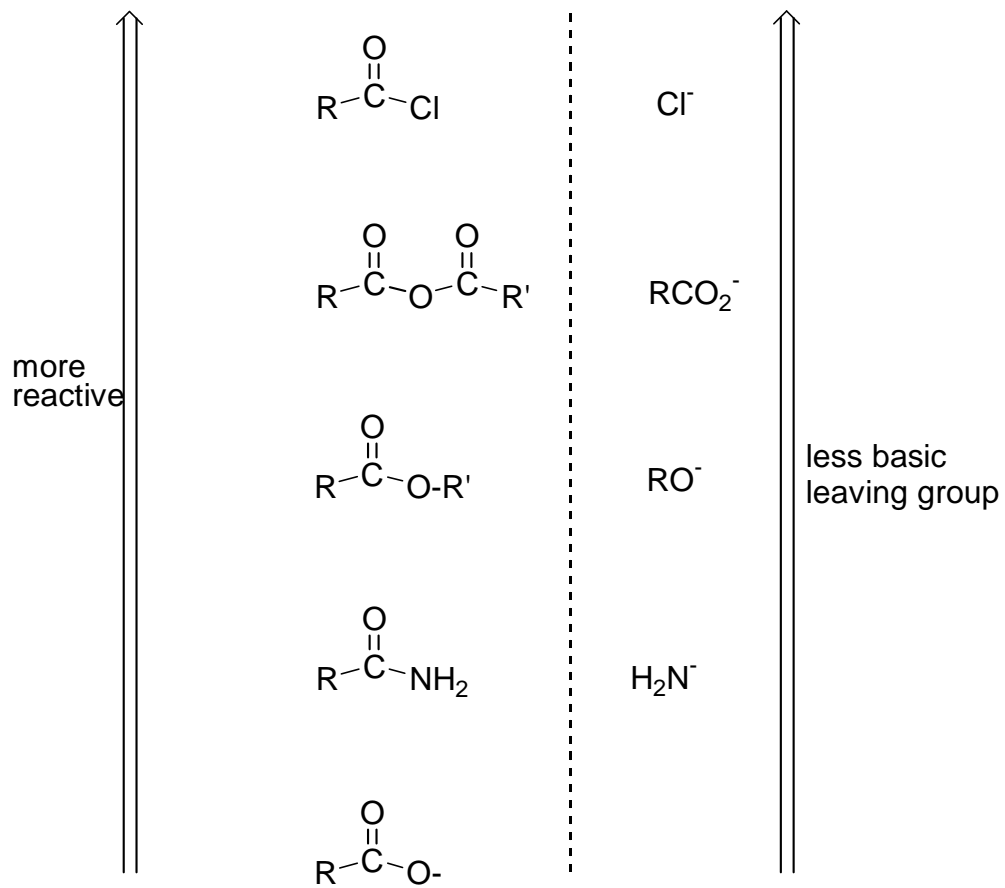

Resonance stabilization also plays a factor in the stability (and hence reactivity) of these systems.

For example amides are resonance stabilized, but when a nucleophile becomes bound, and a tetrahedral intermediate is produced, the resonance stabilization is lost.

This also applies (to a lesser extent) for esters and anhydrides.

In general it is easy to convert more reactive derivatives into less reactive derivatives.

Therefore an acid chloride is easily converted into an anhydride, ester or amide, but an amide can only be hydrolyzed to a carboxylic acid.

*Interconversions of acid derivatives*

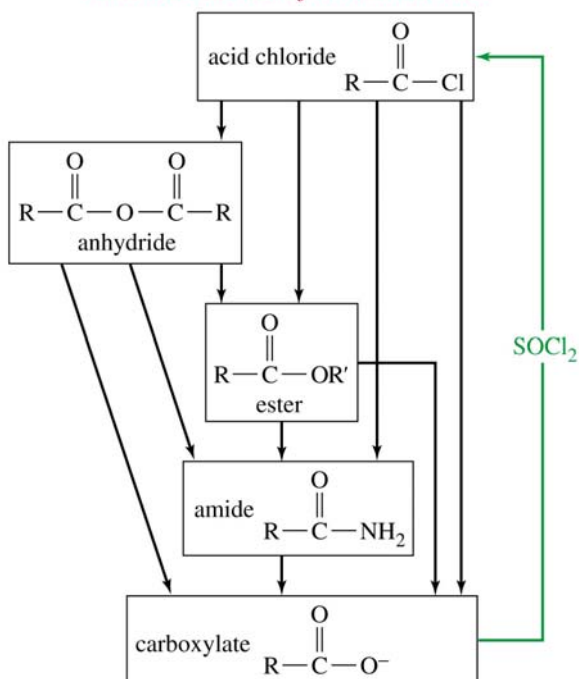

A carboxylic acid is converted to an acid chloride (most reactive derivative) by thionyl chloride.

All these conversions involve **nucleophilic acyl substitution** via the addition elimination mechanism.



Notice the repetitive nature of all these mechanisms.

They work for all the derivatives, just the nucleophile and leaving group is different each time.

### Leaving groups in Nucleophilic Acyl Substitutions

The loss of the alkoxide ion in ester reactions is something we have not seen before.

Alkoxide ions are poor leaving groups in  $S_N1$ ,  $S_N2$  E1 or E2 (alkyl substitution/elimination) reactions, so how do we explain this behavior?

The difference lies partly in the (different) mechanism of the nucleophilic acyl substitution.

The  $S_N2$  mechanism is a one step process, and is neither highly endo- or exothermic.

This is because bond forming and breaking is occurring at the same time. The transition state for this reaction involves the leaving group leaving the molecule, and therefore the reaction rate is very sensitive to the leaving group ability.

A poor leaving group (like alkoxide) gives rise to slow rates (i.e. reaction does not work).

$S_N2$

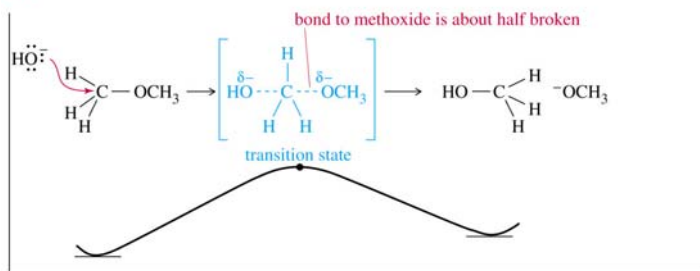

Acyl substitution

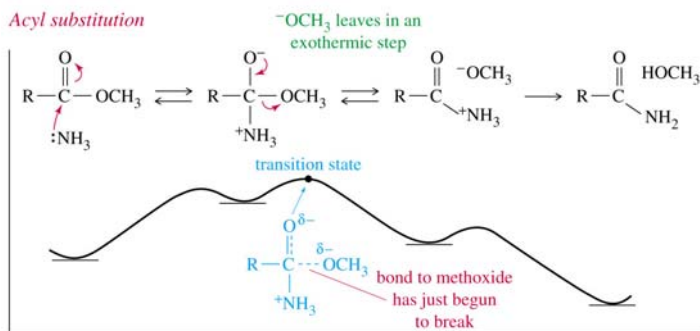

The acyl substitution works with alkoxide as the leaving group since the mechanism is different.

The first step of nucleophilic acyl substitution is the endothermic attack of the nucleophile.

The second step is highly exothermic, and this is where the leaving group (i.e. alkoxide) is expelled from the tetrahedral intermediate.

The **exothermic** nature of this step tells us (Hammond's postulate Ch 4) that this TS should resemble the reactant (tetrahedral intermediate) more than the product (alkoxide ion and new derivative).

This means that the rate is **not influenced** a great deal by the leaving group ability.

Hence nucleophilic acyl substitution can occur with strong bases acting as the leaving group.

### Acid Catalyzed Nucleophilic Acyl Substitution

In the previous examples, a nucleophile attacked the carbonyl group to generate a tetrahedral intermediate.

However some nucleophiles are too weak to directly attack the carbonyl group (especially in the less reactive acid derivatives).

E.g. an alcohol will attack an acid chloride, but not a carboxylic acid.

However we saw that by using a strong acid, an alcohol can react with a carboxylic acid (Fischer esterification, Ch 20) to give an ester.

The strong acid protonates the carbonyl oxygen, and thus activates the carbonyl group to nucleophilic attack, → ester.

A similar mechanism also accounts for transesterification.

### Transesterification

When an ester is treated with another alcohol (in the presence of a strong acid) then **transesterification** occurs - this is where the alcohol part of the ester can be replaced with a new alcohol component.

E.g.

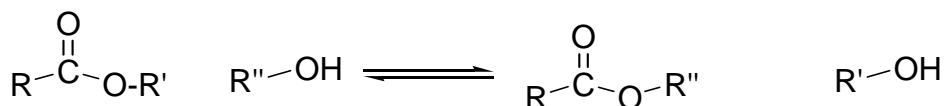

This reaction is equilibrium controlled, and the desired product is encouraged by using a large excess of the desired alcohol (or by removing the undesired alcohol).

This reaction can proceed either by the acid catalyzed mechanism or by the base catalyzed route.

## Hydrolysis of Carboxylic Acids Derivatives

All acid derivatives yield carboxylic acids on hydrolysis.

The hydrolysis (in most cases) can either be acid or base catalyzed.

The reactivity toward hydrolysis varies greatly amongst the derivatives.

### Hydrolysis of Acid Halides and Anhydrides

These are so reactive that they will react with water under neutral conditions.

This can be an annoying side reaction since these compounds can be air (moisture) sensitive.

Hydrolysis can be avoided by using dry nitrogen atmospheres and anhydrous solvents and reagents.

E.g.

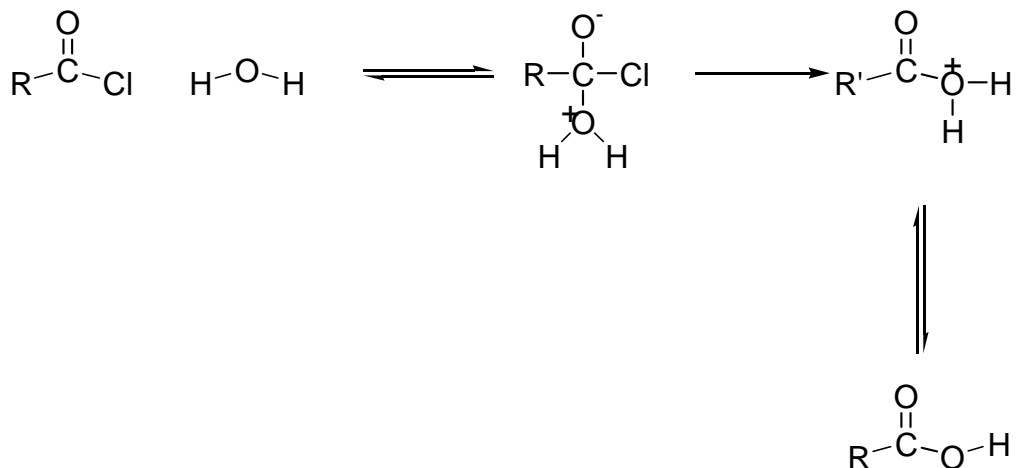

## Hydrolysis of Esters

The acid catalyzed hydrolysis of an ester is simply the reverse reaction of the Fischer esterification.

Addition of excess water drives the equilibrium towards the side of the acid and alcohol.

The basic hydrolysis of esters is also known as **saponification**, and this does not involve the equilibrium process observed for the Fischer esterification.

Hydroxide ion attacks the carbonyl group to give a tetrahedral intermediate, followed by expulsion of the alkoxide ion to generate the acid.

However the basic conditions quickly deprotonate the acid, and the resulting carboxylate is unable to participate in the reverse reaction, and thus there is no equilibrium, the reaction goes to completion.

E.g.

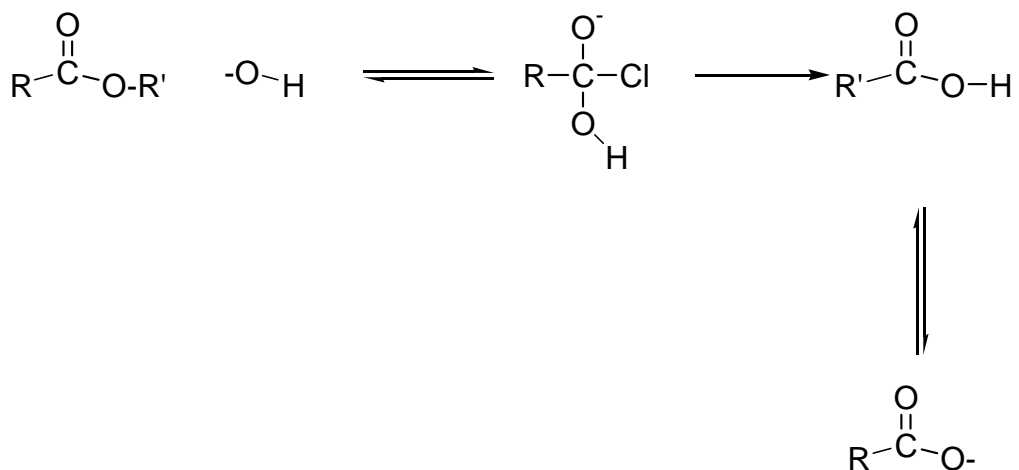

### Hydrolysis of Amides

Amides are the most reluctant derivatives to undergo hydrolysis, but they can be forced to by the use of vigorous conditions such as heating with 6M HCl or 40% NaOH for prolonged periods of time.

E.g.

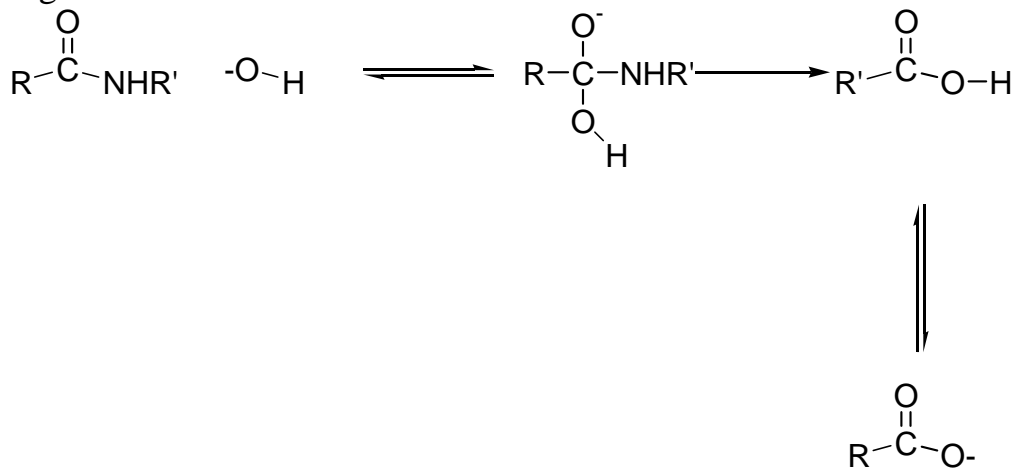

The basic mechanism is similar to that for hydrolysis of an ester, with hydroxide attacking the carbonyl, and the resulting tetrahedral intermediate expels the amide leaving group, that in turn deprotonates the carboxylic acid.

The end products are an amine (ammonia) and a carboxylate ion.

Under **acidic** conditions, the hydrolysis of an amide resembles the acid catalyzed hydrolysis of an ester, with protonation of the carbonyl group giving rise to an activated carbonyl group, that undergoes nucleophilic attack by water.

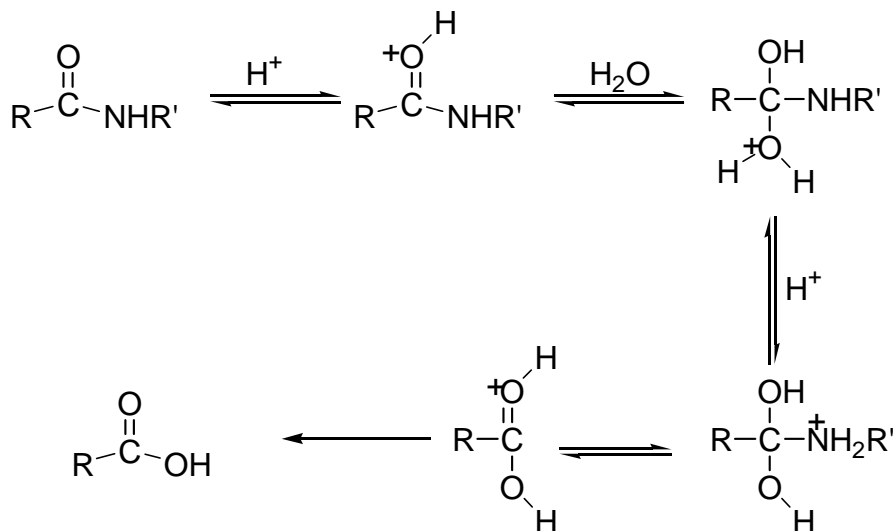

The tetrahedral intermediate produced is deprotonated, and is reprotonated on the amine, thus creating a good leaving group, and then the protonated amine is expelled, and finally deprotonation of the acid generates the ammonium cation and the carboxylate ion.

## Hydrolysis of Nitriles

Nitriles are hydrolyzed to primary amides, and then on to carboxylic acids.

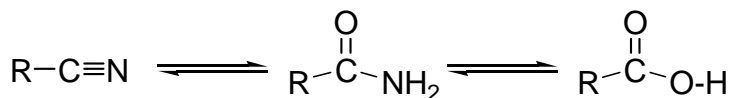

Mild conditions only take this hydrolysis to the amide stage, and more vigorous conditions are required to convert the amide to a carboxylic acid.

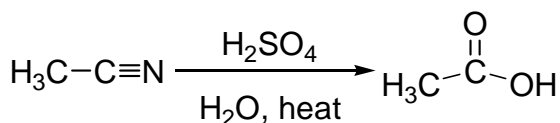
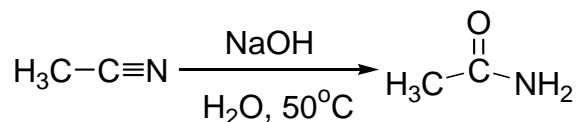

The mechanism for basic hydrolysis of nitriles starts with the attack of hydroxide on the nitrile carbon, followed by protonation on the unstable nitrogen anion.

This generates the enol tautomer of an amide, and this tautomerizes to the more stable amide via deprotonation on oxygen and protonation on nitrogen.

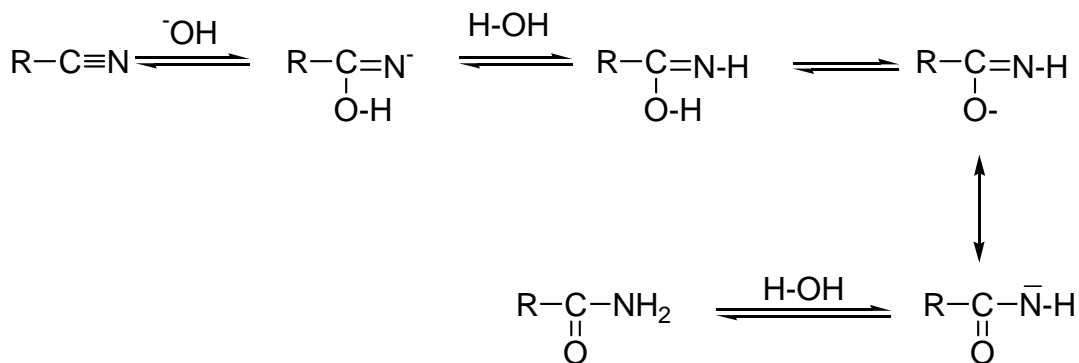

### Reduction of Acid Derivatives

Lithium aluminum hydride will reduce acids, acid chlorides and esters to primary alcohols (Ch 20).

E.g.

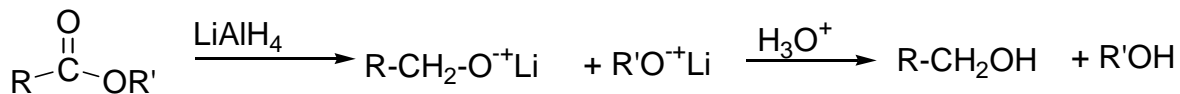

Esters and acid chlorides react through the addition elimination mechanism, generating aldehydes, that are quickly reduced to the primary alcohols.

### Reduction to Aldehydes

Acid chlorides are the most reactive acid derivatives, and can therefore be reduced to aldehydes (and made to stop there) by the action of a mild reducing agent, such as lithium aluminum tri(tbutoxy)hydride (Ch 18 and Ch 20).

E.g.

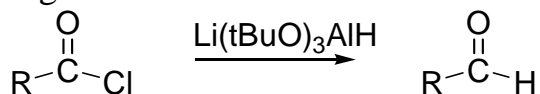

### Reduction to Amines

Lithium aluminum hydride reduces amides, azides and nitriles to amines.

These constitute some of the best synthetic routes to amines (Ch 19).

Azides, primary amides and nitriles generate primary amines on reduction.

Secondary amides are reduced to secondary amines, and tertiary amides produce tertiary amines.

E.g.

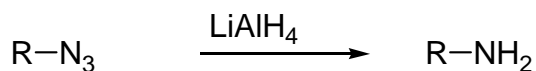
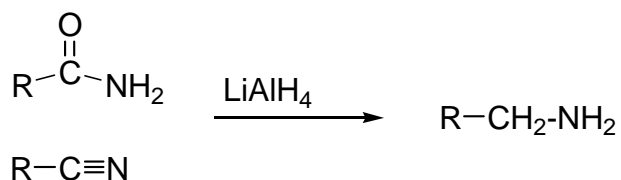

### Acid Derivatives and Organometallic Reagents

Esters and acid chlorides will react twice with Grignard (and organolithium) reagents to produce alkoxides (Ch 10).

Protonation of the alkoxides generates alcohols.

E.g.

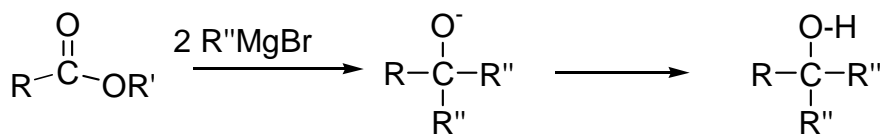

The mechanism involves nucleophilic substitution at the acyl carbon atom.

The carbon nucleophile attacks and the leaving group is expelled from the tetrahedral intermediate, and a ketone is formed.

The second equivalent of organometallic reagent attacks the ketone via nucleophilic addition, generating the alkoxide.

## Nitriles

Organometallic reagents attack the electrophilic carbon of the nitrile group, and generate the metal salt of an imine.

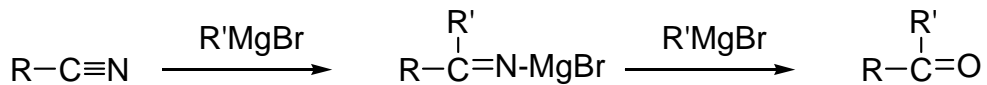

Acid hydrolysis of this salt not only protonates the salt to form an imine, but also hydrolyses the imine to a ketone (Ch 18).

## Summaries

### Acid Chlorides

Acid chlorides are made from the corresponding carboxylic acids, most commonly via reaction of oxalyl chloride or thionyl chloride.

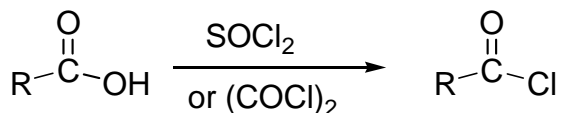

Acid chlorides react quickly with nucleophiles such as water.

They are the most reactive acid derivatives, and are easily converted into any other of the acid derivatives.

E.g.

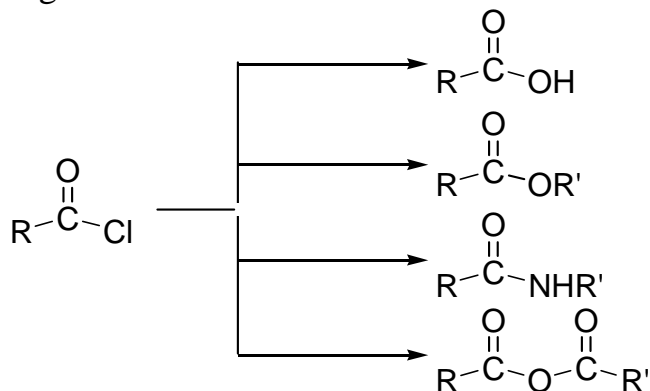

Acid chlorides can be converted into primary alcohols, tertiary alcohols, aldehydes and ketones through the choice of appropriate organometallic reagent (Ch 10, 18 and 21)

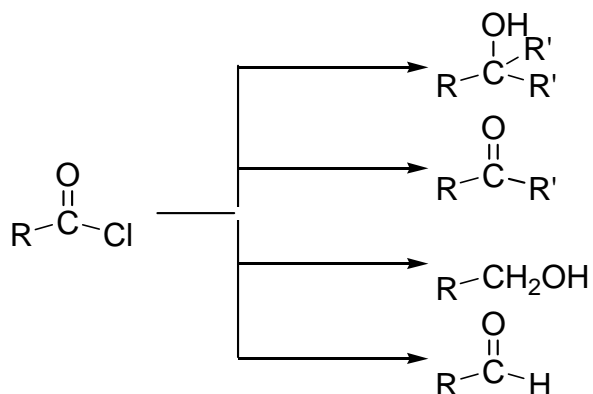

Acid chlorides are used in Friedal Crafts acylation (Ch17).

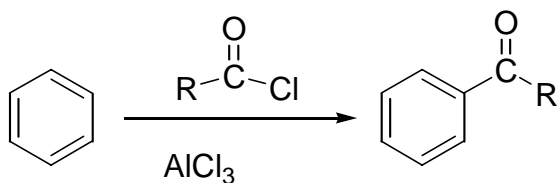

### Acid Anhydrides

Anhydrides are also activated derivatives of carboxylic acids.

They are produced most commonly by the reaction of an acid chloride and a carboxylic acid (or carboxylate).

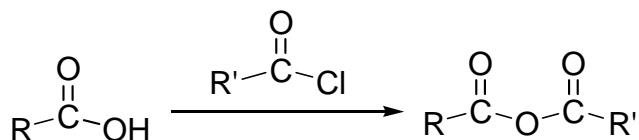

Some cyclic anhydrides can be made by simply heating the diacid.

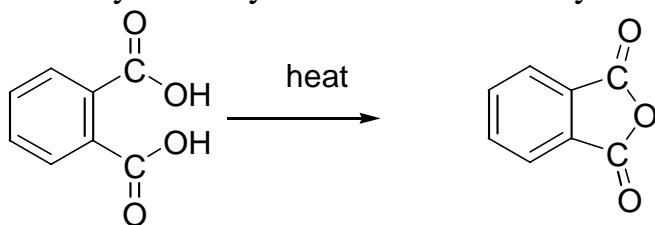

Anhydrides undergo many of the same reactions as acid chlorides.

E.g.

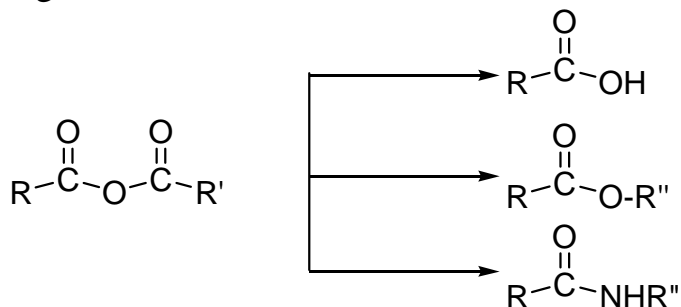

Notice that half of the anhydride is lost during almost all of these reactions.

If the acid is very precious, then this is not the way to go.

### Esters

Esters are generally sweet smelling compounds, and are widely used as flavorings and perfumes.

They are most commonly made via Fischer esterifications using a carboxylic acid and an alcohol.

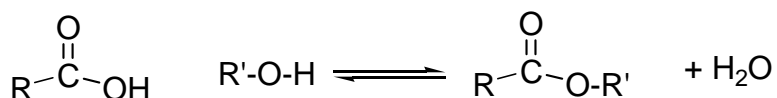

Of course they can be also be made from acid chlorides, anhydrides and other esters (transesterification).

Methyl esters are conveniently made using diazomethane.

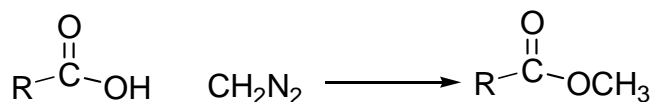

Esters are less reactive than acid halides and anhydrides, and acidic or basic conditions are required for hydrolysis, although an amine can displace the alkoxide group to generate an amide (downhill reaction).

E.g.

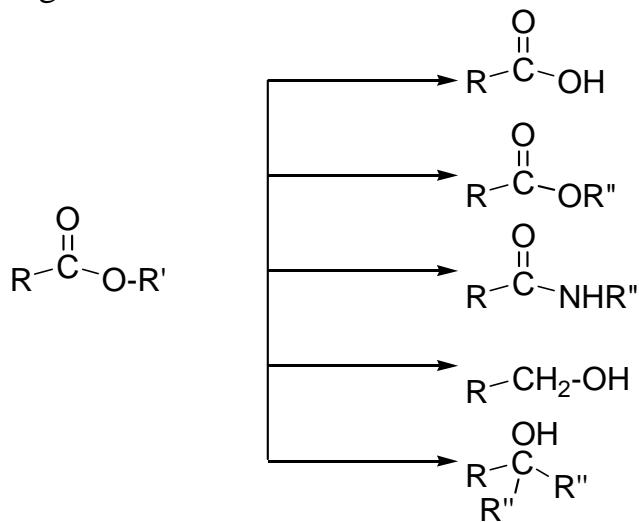

Lactones (cyclic esters) are made from the Fischer esterification where the hydroxyl and carboxylic acid functionalities are in the same molecule.

E.g.

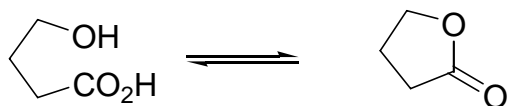

## Amides

These are the least reactive acid derivatives, and are easily formed from any of the other derivatives.

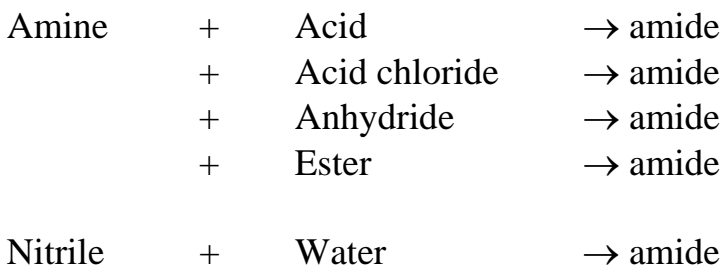

Since amides are so stable (unreactive), they are not easily converted to the other derivatives via nucleophilic acyl substitution.

Their most important synthetic use is their reduction to amines.

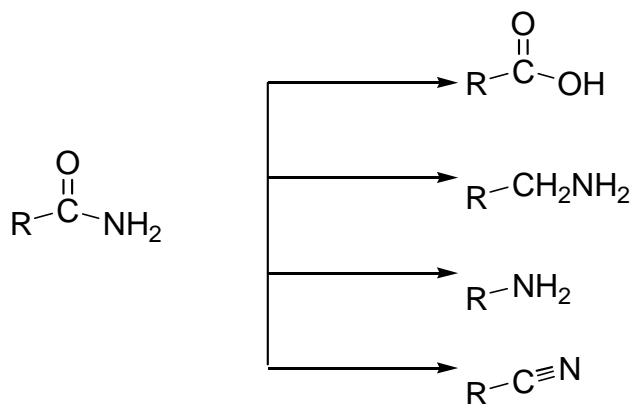

The Hofmann rearrangement can be useful to produce amines from primary amides (with one less carbon).

Since nitriles can be hydrolyzed to primary amides, primary amides can be dehydrated to nitriles.

Most commonly phosphorous pentoxide ( $P_2O_5$ ), or phosphorous oxychloride ( $POCl_3$ ) are used.

Lactams (cyclic amides) are often formed by heating (or dehydrating) amino acids.

E.g.

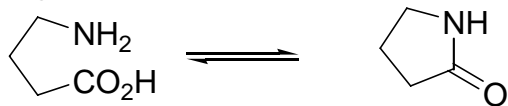

$\beta$ -lactams are the active functionality in modern antibiotics, such as penicillin.

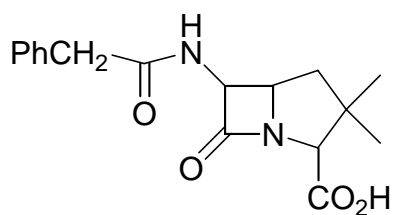

(Penicillin V)

### Nitriles

Despite not containing an acyl group, nitriles are still considered carboxylic acid derivatives since on hydrolysis they form carboxylic acids.

These are most commonly made via the conversion of a carboxylic acid to a primary amide, followed by dehydration.

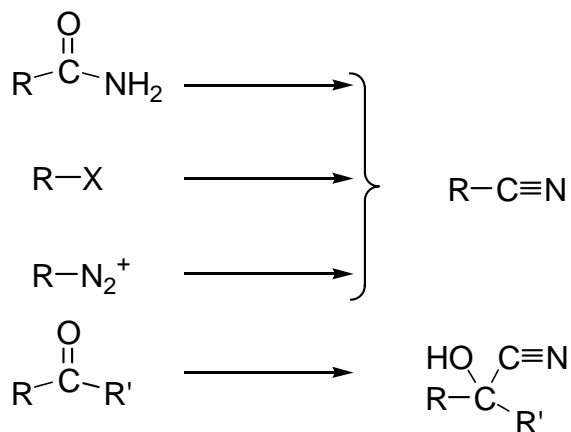

Alkyl nitriles can be prepared by the action of cyanide ion on alkyl halides.

Aryl nitriles are easily made via Diazonium salt formation and Sandmeyer chemistry (CuCN).

Nitriles undergo acidic or basic hydrolysis to primary amides.

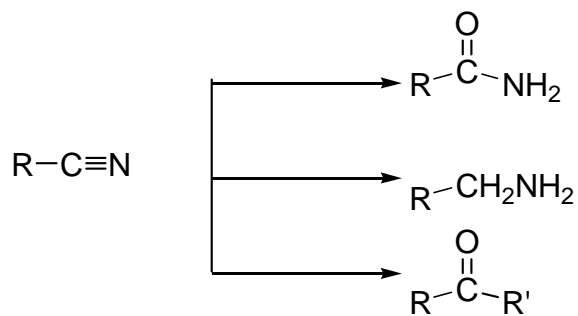

Reduction of a nitrile by lithium aluminum hydride gives a primary amine, and reaction with a Grignard reagent gives a ketone (after acidic hydrolysis).